

## Experimental Nonlocality Proof of Quantum Teleportation and Entanglement Swapping

Thomas Jennewein, Gregor Weihs, Jian-Wei Pan, and Anton Zeilinger

*Institut für Experimentalphysik, Universität Wien Boltzmannngasse 5, 1090 Wien, Austria*

(Received 15 August 2001; published 18 December 2001)

Quantum teleportation strikingly underlines the peculiar features of the quantum world. We present an experimental proof of its quantum nature, teleporting an entangled photon with such high quality that the nonlocal quantum correlations with its original partner photon are preserved. This procedure is also known as entanglement swapping. The nonlocality is confirmed by observing a violation of Bell's inequality by 4.5 standard deviations. Thus, by demonstrating quantum nonlocality for photons that never interacted, our results directly confirm the quantum nature of teleportation.

DOI: 10.1103/PhysRevLett.88.017903

PACS numbers: 03.67.Hk, 03.65.Ud, 42.50.Ct

Quantum state teleportation [1] allows the transfer of the quantum state from one system to another distant one. This system becomes the new original as it carries all information the original did and the state of the initial particle is erased, as necessitated by the quantum no-cloning theorem [2]. This is achieved via a combination of an entangled state and a classical message.

The most interesting case of quantum teleportation occurs when the teleported state itself is entangled. There the system to be teleported does not even enjoy its own state. This procedure is also known as "entanglement swapping" [3] because (Fig. 1) one starts with two pairs of entangled photons 0–1 and 2–3 and subjects photons 1 and 2 to a Bell-state measurement by which photons 0 and 3 also become entangled. As suggested by Peres [4] this even holds if the "entangling" Bell-state measurement is performed after photons 0 and 3 have already been registered. Entanglement swapping was shown [5] in a previous experiment, yet the low photon-pair visibility prevented a violation of a Bell's inequality [6] for photons 0 and 3, which is a definitive test. This is the case, because if significant information about the state of the teleported photon 1 were gained in the teleportation procedure, the measurements on photons 0 and 3 would not violate Bell's inequality. This fact is substantiated by the quantum no-cloning theorem [2]. Therefore, the violation of Bell's inequality confirms that the state of photon 1 was even undefined in a fundamental way and Alice could not have played any kind of tricks to make the results look like successful teleportation. The experiment presented here provides now such a definitive proof of the quantum nature of teleportation.

In the present work quantum state teleportation is implemented in terms of polarization states of photons and hence relies on the entanglement of the polarization of photon pairs prepared in one of the four Bell states, e.g.,

$$|\Psi_{01}^-\rangle = \frac{1}{\sqrt{2}}(|H\rangle_0|V\rangle_1 - |V\rangle_0|H\rangle_1). \quad (1)$$

A schematic overview of our quantum teleportation scheme is given in Fig. 1.

Initially, the system is composed of two independent entangled states and can be written in the following way:

$$|\Psi_{\text{total}}\rangle = |\Psi^-\rangle_{01} \otimes |\Psi^-\rangle_{23}. \quad (2)$$

Including Eq. (1) in (2) and rearranging the resulting terms by expressing photon 1 and photon 2 in the basis of Bell states leads to

$$|\Psi_{\text{total}}\rangle = \frac{1}{2}[|\Psi^+\rangle_{03}|\Psi^+\rangle_{12} - |\Psi^-\rangle_{03}|\Psi^-\rangle_{12} - |\Phi^+\rangle_{03}|\Phi^+\rangle_{12} + |\Phi^-\rangle_{03}|\Phi^-\rangle_{12}]. \quad (3)$$

Alice subjects photons 1 and 2 to a measurement in a Bell-state analyzer (BSA), and if she finds them in the state  $|\Psi^-\rangle_{12}$ , then photons 0 and 3 measured by Bob will be in the entangled state  $|\Psi^-\rangle_{03}$ . If Alice observes any of the other Bell states for photons 1 and 2, photons 0 and 3 will also be perfectly entangled correspondingly. We stress that photons 0 and 3 will be perfectly entangled for any result of the BSA, and therefore it is not necessary to apply a unitary operation to the teleported photon 3 as in the standard teleportation protocol. But it is certainly necessary for Alice to communicate to Victor her Bell-state measurement result. This enables him to sort Bob's data into four subsets, each one representing the results for one of the four maximally entangled Bell states.

Therefore with suitable polarization measurements on photons 0 and 3, Victor will obtain a violation of Bell's inequality and confirm successful quantum teleportation for each of the four subsets separately. In our experiment, Alice was restricted to identifying only the state  $|\Psi^-\rangle_{12}$  due to technical reasons. This reduction of the teleportation efficiency to 25% does not influence the fidelity. A large disturbance of the fidelity would perturb the teleported entanglement to such a degree that a violation of Bell's inequality could no longer be achieved. As explained elsewhere [7] teleportation efficiency measures the fraction of cases in which the procedure is successful and the fidelity characterizes the quality of the teleported state in the successful cases. For example, loss of a photon in our case leads outside the two-state Hilbert space used and thus reduces the efficiency and not the fidelity.

It has been shown that using linear optical elements the efficiency of any BSA is limited to maximally 50% [8]. A configuration where photons 1 and 2 are brought to interference at a 50:50 beam splitter is able to identify two

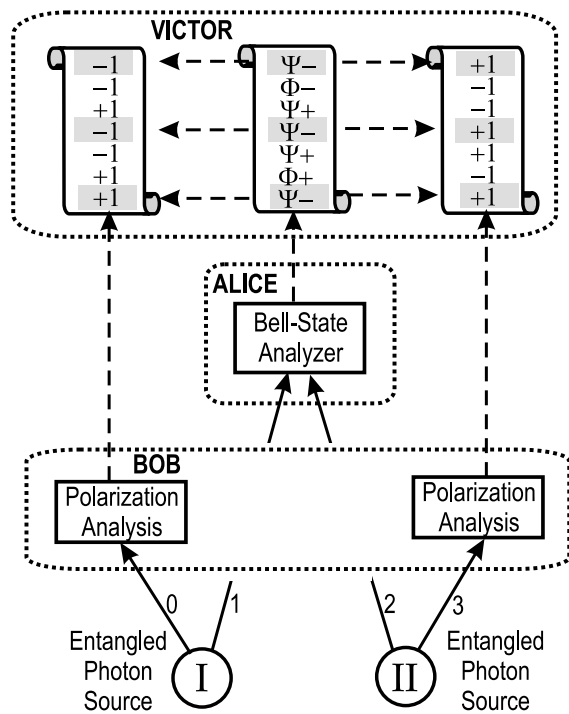

FIG. 1. Entanglement swapping version of quantum teleportation. Two entangled pairs of photons 0–1 and 2–3 are produced in the sources I and II, respectively. One photon from each pair is sent to Alice who subjects them to a Bell-state measurement, projecting them randomly into one of four possible entangled states. Alice records the outcome and hands it to Victor. This procedure projects photons 0 and 3 into a corresponding entangled state. Bob performs a polarization measurement on each photon, choosing freely the polarizer angle and recording the outcomes. He hands his results also to Victor, who sorts them into subsets according to Alice’s results, and checks each subset for a violation of Bell’s inequality. This shows whether photons 0 and 3 became entangled although they never interacted in the past. This procedure can be seen as teleportation either of the state of photon 1 to photon 3 or of the state of photon 2 to photon 0. Interestingly, the quantum prediction for the observations does not depend on the relative space-time arrangement of Alice’s and Bob’s detection events.

Bell states exactly, and the remaining two only together (demonstrated in [9]). Particularly easy to identify is the  $|\Psi^-\rangle_{12}$  state, as only in this case the two photons can be detected in separate outputs of the beam splitter.

The setup of our system is shown in Fig. 2. Two separate polarization entangled photon pairs are produced via type-II down-conversion in barium borate (BBO) [10] pumped by UV laser pulses at a wavelength of 394 nm, a pulse width of  $\approx 200$  fs, a repetition rate of 76 MHz, and an average power of 370 mW. The entangled photons had a wavelength of 788 nm. Through spectral filtering with a  $\Delta\lambda_{FWHM} = 3.5$  nm for photons 0 and 3 and  $\Delta\lambda_{FWHM} = 1$  nm for photons 1 and 2, the coherence time of the photons was made to exceed the pulse width of the UV laser, making the two entangled photon pairs indistinguishable in time, a necessary criterion for

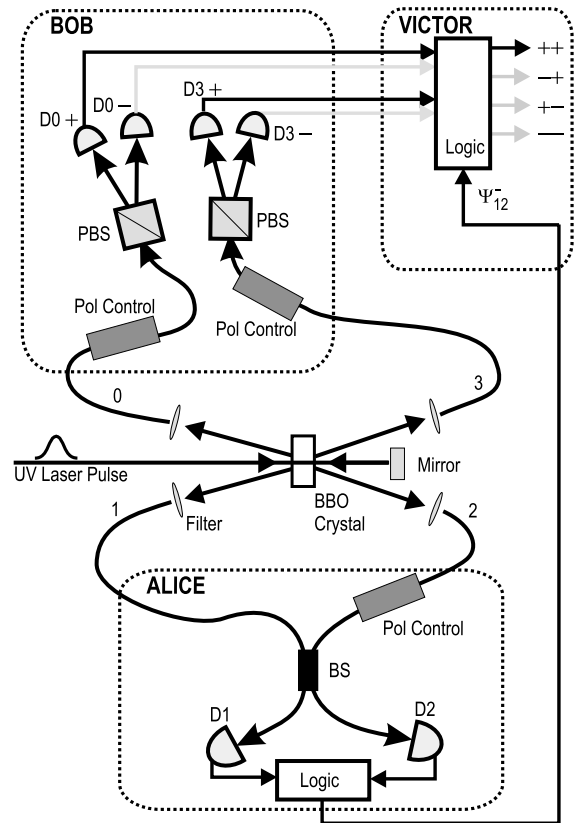

FIG. 2. Setup of the experiment. The two entangled photon pairs were produced by down-conversion in barium borate (BBO), pumped by femtosecond UV laser pulses traveling through the crystal in opposite directions. After spectral filtering, all photons were collected in single-mode optical fibers for further analysis and detection. Single-mode fibers offer the high benefit that the photons remain in a perfectly defined spatial mode allowing high fidelity interference. For performing the Bell-state analysis, photons 1 and 2 interfered at a fiber beam splitter, where one arm contained a polarization controller for compensating the polarization rotation introduced by the optical fibers. In order to optimize the temporal overlap between photon 1 and 2 in the beam splitter, the UV mirror was mounted on a motorized translation stage. Photons 0 and 3 were sent to Bob’s two-channel polarizing beam splitters for analysis, and the required orientation of the analyzers was set with polarization controllers in each arm. All photons were detected with silicon avalanche photodiodes, with a detection efficiency of about 40%. Alice’s logic circuit detected coincidences between detectors D1 and D2. It is essential that she passes the result as a classical signal to Victor, who determines whether Bob’s detection events violate Bell’s inequality.

interfering photons from independent down-conversions [11]. The registered event rate of photon pairs was about 2000 per sec before the Bell-state analyzer (Alice) and the polarizing beam splitter (Bob). The rate of obtaining a fourfold photon event for the teleportation was about 0.0065 per sec. Each single correlation measurement for one setting of the polarizers lasted 16 000 sec. The polarization alignment of the optical fibers performed before each measurement proved to be stable within  $1^\circ$  for 24 h.

The nondeterministic nature of the photon pair production implies an equal probability for producing two photon pairs in separate modes (one photon each in modes 0, 1, 2, 3) or two pairs in the same mode (two photons each in modes 0 and 1 or in modes 2 and 3). The latter can lead to coincidences in Alice's detectors behind her beam splitter. We exclude these cases by accepting events only where Bob registers a photon each in mode 0 and mode 3. It was shown by Zukowski [12] that despite these effects of the nondeterministic photon source experiments of our kind still constitute valid demonstrations of nonlocality in quantum teleportation.

The entanglement of the teleported state was characterized by several correlation measurements between photons 0 and 3 to estimate the fidelity of the entanglement. As is customary the fidelity  $F = \langle \Psi^- | \rho | \Psi^- \rangle$  measures the quality of the observed state  $\rho$  compared to the ideal quantum case  $|\Psi^- \rangle$ . The experimental correlation coefficient  $E_{\text{exp}}$  is related to the ideal one  $E_{\text{QM}}$  via  $E_{\text{exp}} = [(4F - 1)/3]E_{\text{QM}}$  [13]. The correlation coefficients are defined as  $E = (N_{++} - N_{+-} - N_{-+} + N_{--}) / \sum N_{ij}$ , where  $N_{ij}(\phi_0, \phi_3)$  are the coincidences between the  $i$  channel of the polarizer of photon 0 set at angle  $\phi_0$ , and the  $j$  channel of the polarizer of photon 3 set at angle  $\phi_3$ . The results (Fig. 3) show the high fidelity of the teleported entanglement.

The Clauser-Horne-Shimony-Holt (CHSH) inequality [14] is a variant of Bell's inequality, which overcomes the inherent limits of a lossy system using a fair sampling hypothesis. It requires four correlation measurements performed with different analyzer settings. The CHSH inequality has the following form:

$$S = |E(\phi'_0, \phi'_3) - E(\phi'_0, \phi''_3)| + |E(\phi''_0, \phi'_3) + E(\phi''_0, \phi''_3)| \leq 2, \quad (4)$$

where  $S$  is the "Bell parameter,"  $E(\phi_0, \phi_3)$  is the correlation coefficient for polarization measurements where  $\phi_0$  is the polarizer setting for photon 0, and  $\phi_3$  is the setting for photon 3 [15]. The quantum mechanical prediction for photon pairs in a  $\Psi^-$  state is  $E^{\text{QM}}(\phi_0, \phi_3) = -\cos[2(\phi_0 - \phi_3)]$ . The settings  $(\phi'_0, \phi'_3, \phi''_0, \phi''_3) = (0^\circ, 22.5^\circ, 45^\circ, 67.5^\circ)$  maximize  $S$  to  $S^{\text{QM}} = 2\sqrt{2}$ , which clearly violates the limit of 2 and leads to a contradiction between local realistic theories and quantum mechanics [6]. In our experiment, the four correlation coefficients between photons 0 and 3 gave the following results:  $E(0^\circ, 22.5^\circ) = -0.628 \pm 0.046$ ,  $E(0^\circ, 67.5^\circ) = +0.677 \pm 0.042$ ,  $E(45^\circ, 22.5^\circ) = -0.541 \pm 0.045$ , and  $E(45^\circ, 67.5^\circ) = -0.575 \pm 0.047$ . Hence,  $S = 2.421 \pm 0.091$  which clearly violates the classical limit of 2 by 4.6 standard deviations as measured by the statistical error. The differences in the correlation coefficients come from the higher correlation fidelity for analyzer settings closer to  $0^\circ$  and  $90^\circ$ , as explained in Fig. 3.

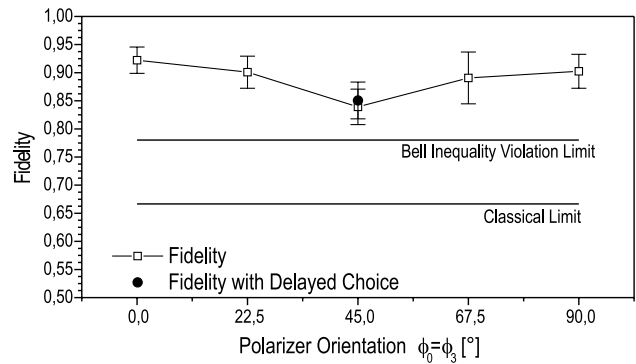

FIG. 3. Observed entanglement fidelity obtained through correlation measurements between photons 0 and 3, which is a lower bound for the fidelity of the teleportation procedure.  $\phi_0$  ( $\phi_3$ ) is the setting of the polarization analyzer for photon 0 (photon 3) and  $\phi_0 = \phi_3$ . The minimum fidelity of 0.84 is well above the classical limit of  $2/3$  and also above the limit of 0.79 necessary for violating Bell's inequality. The fidelity is maximal for  $\phi_0 = \phi_3 = 0^\circ, 90^\circ$  since this is the original basis in which the photon pairs are produced ( $|HV\rangle$  or  $|VH\rangle$ ). For  $\phi_0 = \phi_3 = 45^\circ$  the two processes must interfere ( $|HV\rangle - |VH\rangle$ ) which is non-perfect due effects such as mismatched photon collection or beam walk-off in the crystals. This leads to a fidelity variation for the initially entangled pairs, which fully explains the observed variation of the shown fidelity. Thus we conclude that the fidelity of our Bell-state analysis procedure is about 0.92, independent of the polarizations measured. The square dots represent the fidelity for the case that Alice's and Bob's events are spacelike separated; thus no classical information transfer between Alice and Bob can influence the results. The circular dot is the fidelity for the case that Alice's detections are delayed by 50 ns with respect to Bob's detections. This means that Alice's measurement projects photons 0 and 3 in an entangled state, at a time after they have already been registered.

The travel time from the source to the detectors was equal within 2 ns for all photons. Both Alice's and Bob's detectors were located next to each other, but Alice and Bob were separated by about 2.5 m, corresponding to a luminal signaling time of 8 ns between them. Since the time resolution of the detectors is  $<1$  ns, Alice's and Bob's detection events were spacelike separated for all measurements.

A seemingly paradoxical situation arises—as suggested by Peres [4]—when Alice's Bell-state analysis is delayed long after Bob's measurements. This seems paradoxical, because Alice's measurement projects photons 0 and 3 into an entangled state after they have been measured. Nevertheless, quantum mechanics predicts the same correlations. Remarkably, Alice is even free to choose the kind of measurement she wants to perform on photons 1 and 2. Instead of a Bell-state measurement she could also measure the polarizations of these photons individually. Thus depending on Alice's later measurement, Bob's earlier results indicate either that photons 0 and 3 were entangled or photons 0 and 1 and photons 2 and 3. This means that the physical interpretation of his results depends on Alice's later decision.

Such a delayed-choice experiment was performed by including two 10 m optical fiber delays for both outputs of the BSA. In this case photons 1 and 2 hit the detectors delayed by about 50 ns. As shown in Fig. 3, the observed fidelity of the entanglement of photon 0 and photon 3 matches the fidelity in the nondelayed case within experimental errors. Therefore, this result indicates that the time ordering of the detection events has no influence on the results and strengthens the argument of Peres [4]: *This paradox does not arise if the correctness of quantum mechanics is firmly believed.*

One might question the “independence” of photons 1 and 2 which interfere in the BSA, since all photons are produced by down-conversion from one and the same UV laser pulse, and the photons could take on a phase coherence from the UV laser. Note that the UV mirror was placed 13 cm behind the crystal, which greatly exceeds the pump pulse width of  $\sim 60 \mu\text{m}$ . We performed a Mach-Zehnder interference experiment of a laser on the BSA to measure the relative phase drifts due to instabilities of the optical paths. The statistical analysis of the temporal phase variation was done using the Allan variance [16], which we suggest as an appropriate measure. Accordingly, the phase drifted in a random walk behavior, accumulated a  $1\sigma$  statistical drift of one wavelength within 400 s, and had a maximum drift of 15 wavelengths during 10 h. In a single measurement which lasted 16 000 sec, any (hypothetical) phase relation between the two photons that interfered in the BSA would have been completely washed out. Therefore the contribution of such a phase relation to the outcome of the experiments can be ruled out.

Our work, besides definitely confirming the quantum nature of teleportation [17], is an important step for future quantum communication and quantum computation protocols. Entanglement swapping is the essential ingredient in quantum repeaters [18], where it can be used to establish entanglement between observers separated by larger distances as were possible using links with individual pairs only.

This work was supported by the Austrian Science Fund (FWF) and the “QuComm” IST-FET project of the European Commission.

- 
- [1] C. H. Bennett, G. Brassard, C. Crépeau, R. Jozsa, A. Peres, and W. K. Wootters, Phys. Rev. Lett. **70**, 1895 (1993).
  - [2] V. Buzek and M. Hillery, Phys. Rev. A **54**, 1844 (1996).
  - [3] M. Żukowski, A. Zeilinger, M. A. Horne, and A. K. Ekert, Phys. Rev. Lett. **71**, 4287 (1993).
  - [4] A. Peres, J. Mod. Opt. **47**, 139 (2000).
  - [5] J.-W. Pan, D. Bouwmeester, H. Weinfurter, and A. Zeilinger, Phys. Rev. Lett. **80**, 3891 (1998).
  - [6] J. Bell, Physics **1**, 195 (1964).
  - [7] D. Bouwmeester, J.-W. Pan, H. Weinfurter, and A. Zeilinger, J. Mod. Opt. **47**, 279 (2000).
  - [8] J. Calsamiglia and N. Lütkenhaus, Appl. Phys. B **72**, 67 (2001).
  - [9] K. Mattle, H. Weinfurter, P. G. Kwiat, and A. Zeilinger, Phys. Rev. Lett. **76**, 4656 (1996).
  - [10] P. G. Kwiat, K. Mattle, H. Weinfurter, A. Zeilinger, A. Sergienko, and Y. Shih, Phys. Rev. Lett. **75**, 4337 (1995).
  - [11] M. Żukowski, A. Zeilinger, and H. Weinfurter, Ann. N.Y. Acad. Sci. **755**, 91 (1995).
  - [12] M. Żukowski, Phys. Rev. A **61**, 022109 (2000).
  - [13] Evidently for a full characterization of  $F$  one would have to perform many more measurements. Anyhow our observed values of  $F$  give a reasonable estimate.
  - [14] J. F. Clauser, M. A. Horne, A. Shimony, and R. A. Holt, Phys. Rev. Lett. **23**, 880 (1969).
  - [15] A. Aspect, P. Grangier, and G. Roger, Phys. Rev. Lett. **49**, 91 (1982).
  - [16] D. W. Allan, IEEE Trans. Ultrason. Ferroelectr. Freq. Control **34**, 647 (1987).
  - [17] M. Żukowski, Phys. Rev. A **62**, 032101 (2000).
  - [18] H.-J. Briegel, W. Dür, J. I. Cirac, and P. Zoller, Phys. Rev. Lett. **81**, 5932 (1998).